



# Butterfly valve

## Type VSS LT (Low Temperature)

Si-210 EN

Edition: 2006-04

Nominal pressure	— PN 10 - 25
Nominal size	— DN 80 - 500
Material	— Stainless steel

### The SOMAS butterfly valve type VSS LT

- **Advanced triple eccentric design**
  - **is designed for applications at temperatures down to -196°C (-320°F).**
  - **has a tightness class in accordance with IEC 534-4 Class V as standard.**
  - **has a solid seat made of stainless steel.**
  - **has an extended bonnet and the stuffing box located at the top to prevent freezing and allow easy maintenance.**
- Option**
- **Seat made of reinforced PTFE (which gives a tightness class in accordance with IEC 534-4VI)**

The SOMAS butterfly valve, type VSS LT, is a control-, on/off- and manually operated valve. The valve is designed to handle a wide range of liquids, gases and steam at temperatures down to -196°C (-320°F).

The VSS LT-valve can be mounted between flanges and also supplied in lugged design.

The valves have an advanced triple eccentric design including a unique shape of the disc allows the use of a solid stainless steel seat. The solid seat remains unaffected by high flow velocities and a good valve function is achieved even on difficult applications.

The SOMAS valves are delivered ready for installation and operation.

The valve assemblies are delivered factory tested as complete units with actuators, positioners and accessories.



Butterfly valve, type VSS,  
with extended bonnet and  
actuator Type RC



### Tightness class

The tightness class is related to the chosen material in the seat ring.

Metal seat (Code C) IEC 534-4 V (ANSI B16-104 Class V)  
 PTFE-seat\* (Code P) IEC 534-4 VI (ANSI B16-104 Class VI)

\* PTFE Fibre-glass 15%

### Flow characteristics

100% Flow

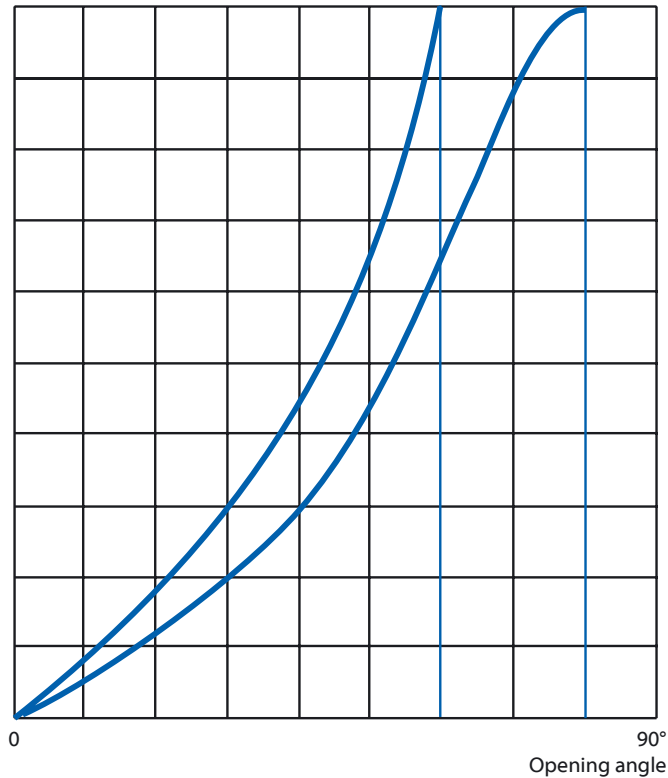

### Temperature range

For applications down to -196°C (-320°F) and up to 200°C (392°).

### Degreasing

The valve can be degreased and packed in plastic bags and marked for oxygen service.

### Certification

The valves can be delivered with certificates according to DIN50049-3.1B or equal. Other types of certificates on request.

Certificates for oxygen service on request.

### Flange standard

The SOMAS butterfly valves type VSS LT in above mentioned sizes are equipped with flanges which can be drilled for PN 10, PN 16, PN 20 and PN 25.

Drilling according to ANSI, BS, etc. is also possible.

When ordering, please state the pressure rating of the counter flanges. See valve specification system, code 11.

### Face to face

Face to face according to the EN 558-1 series 20 and EN 558-2 series 20.

### Capacity factor KV and Resistance factor ζ

DN	Opening angle									ζ 90°
	10°	20°	30°	40°	50°	60°	70°	80°	90°	
80	14	31	48	73	108	165	203	235	205	1.18
100	21	45	70	107	158	240	324	375	326	1.13
125	35	75	116	177	262	400	520	605	523	1.06
150	50	108	168	256	379	580	780	905	784	0.98
200	89	193	299	457	675	1030	1390	1610	1397	0.99
250	142	307	476	727	1076	1650	2211	2555	2222	0.95
300	207	446	692	1058	1566	2400	3219	3720	3235	0.93
350	279	602	934	1427	2111	3230	4341	5021	4362	0.95
400	371	800	1242	1898	2809	4300	5775	6675	5805	0.91
450	482	1039	1618	2472	3661	5630	7555	8732	7594	0.90
500	584	1258	1951	2981	4413	6760	9071	10485	9117	0.90

Relation between Kv and Cv:  $K_v=0.86C_v$

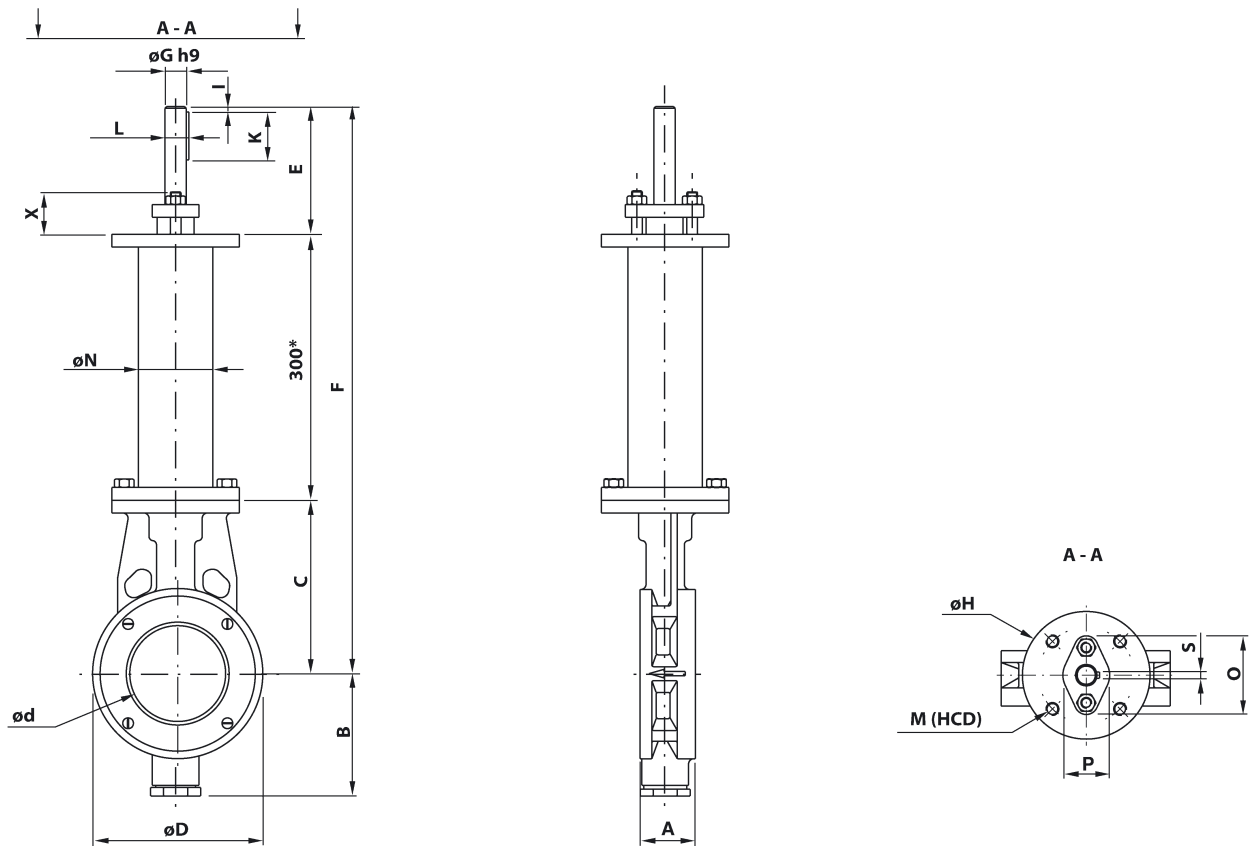

\* Other lengths available on request

Butterfly valve, type VSS LT (Low Temperature)

DN	A	B	C	$\phi d$	$\phi D$	E	F	$\phi G$	H	I	K	L	M (HCD)	$\phi N$	O	P	S	X	Weight	
80	50	105	150	70	133	120	570	20	120	5	45	22.5	M12	90	63	74	44	6	40	
100	52	115	163	90	160	120	583	20	120	5	45	22.5	M12	90	63	74	44	6	40	
125	56	130	175	116	190	120	595	20	120	5	45	22.5	M12	90	63	74	44	6	40	
150	56	140	195	140	215	120	615	25	120	5	45	28	M12	90	63	78	50	8	40	
200	60	175	235	187	270	120	655	25	120	5	45	28	M12	90	63	78	50	8	40	
250	68	205	275	236	324	135	710	30	150	5	60	33	M12	120	90	92	58	8	50	
300	78	240	290	285	375	135	725	35	150	5	50	38	M12	120	90	100	64	10	50	
350	78	310	315	331	435	135	750	40	150	5	50	43	M12	120	90	108	70	12	50	
400	102	340	340	382	490	210	850	50	150	10	80	53.5	M12	120	90	124	82	14	50	
450	114	385	370	429	535	210	880	50	150	10	80	53.5	M12	120	90	124	82	14	50	
500	127	415	400	479	590	210	910	60	200	5	90	64	M16	160	125	147	96	18	60	

## Max. allowable pressure drops

Max. allowable pressure drops as below are valid at 20°C (68°F) at -196°C (-320°F)

Nominal size DN	PN	Max. pressure drop, bar at opening angle			Torque min. at $\Delta p$		Torque min. at $\Delta p$		Torque max. shaft Nm	Max. pressure drop, bar at opening angle		
		0	60°	80°	bar	Nm	bar	Nm		0	60°	80°
80	25	25	13	4.4	$\leq 10$	100	$> 10$	120	220	15	7.8	2.7
100	25	25	13	4.4	$\leq 10$	120	$> 10$	165	220	15	7.8	2.7
125	25	25	15	5.8	$\leq 10$	180	$> 10$	220	220	15	9.0	3.5
150	25	25	9.0	2.7	$\leq 10$	200	$> 10$	250	350	15	5.4	1.6
200	25	25	4.3	1.1	$\leq 10$	250	$> 10$	290	350	15	2.6	0.66
250	25	25	3.6	1.05	$\leq 10$	400	$> 10$	500	620	15	2.2	0.63
300	25	25	3.6	0.93	$\leq 10$	500	$> 10$	620	975	15	2.2	0.56
350	25	20	3.6	1.09	$\leq 8$	800	$> 8$	1000	1500	12	2.2	0.65
400	25	20	4.7	1.43	$\leq 8$	1000	$> 8$	1350	2800	12	2.8	0.86
450	25	16	3.4	0.95	$\leq 7$	1350	$> 7$	1900	2800	9.6	2.0	0.57
500	25	15	4.4	1.19	$\leq 6$	1900	$> 6$	2700	5000	9.0	2.7	0.72



## Selection table, VSS

Valve DN	Shaft Ø (mm)	Pneumatic actuators						Manual operation	
		Double acting		Spring return				Hand lever	Gear unit
		5,5 bar	4 bar	Spring closes		Spring opens			
				5,5 bar	4 bar	5,5 bar	4 bar		
80	20	A13	A21	A23-SC	A23-SC	A23-SO	A23-SOL	HV41	M10/F07
100	20	A21	A22	A24-SC	A24-SC	A24-SO	A24-SOL	HV41	M10/F07
125	20	A22	A22	A24-SC	A24-SC	A24-SO	A24-SOL	HV41	M10/F07
150	25	A22	A22	A24-SC	A24-SC	A24-SO	A24-SOL		M10/F07
200	25	A22	A22	A24-SC	A24-SC	A24-SO	A24-SOL		M10/F07
250	30	A23	A31	A33-SC	A33-SC	A33-SO	A33-SOL		M12/F12
300	35	A31	A32	A33-SC	A33-SC	A33-SO	A33-SOL		M12/F12
350	40	A32	A32	A34-SC	A34-SC	A34-SO	A34-SOL		M12/F12
400	50	A32	A33	A43-SC	A43-SC	A43-SO	A43-SOL		M14/F14
450	50	A41	A34	A43-SC	A43-SC	A43-SO	A43-SOL		M14/F14
500	60	A41	A42	A44-SC	A44-SC	A44-SO	A44-SOL		M15/F16

### Further technical information

Technical data for the materials used in the SOMAS valves, flange standard, steam data, etc. can be found in section 6 of the SOMAS catalogue.

### For ordering

State desired valve according to the valve specification system below as well as type of actuator, positioner and accessories.

### Actuators and accessories

The valves can be fitted with SOMAS manual, on/off or control actuators in accordance with the selection table above. The valves will then be delivered as tested shut-off or control units ready for installation.

Check sections 4 and 5 of the SOMAS catalogue, where positions, limit switches and solenoid valves are also presented.

We can also fit other types of actuators and accessories in accordance with your specification.

### Valve specification system

**VSS LT - A 5 - A A C - D 4 2 - DN... - PN...**

1                      2    3                      4    5    6                      7    8    9                      10                      11

- |  |   |  |
|--|---|--|
| 1 Valve type<br>VSS LT (Low Temperature)                           | 5 Material – disc<br>A = SS 2343-12   | 8 Bearings – valve body/shaft<br>4 = Rulon |
| 2 Valve body design<br>A = Wafer type<br>F = Lugs according to DIN | 6 Material - seat ring<br>C = 1.4462 (metal seat, 3 pcs.)<br>R = PTFE (design for Cryo) | 9 Stuffing box<br>2 = PTFE                 |
| 3 Nominal pressure<br>4 = PN20<br>5 = PN25                         | 7 Material – shaft<br>D = 1.4435  | 10 Valve dimension, DN                     |
| 4 Material - valve body<br>A = SS 2343-12                          |   | 11 Drilling, counter flanges               |

*SOMAS reserves the right to make improvements without prior notice.*



**SOMAS**<sup>®</sup>  
P.O. Box 107, SE-661 23 SÄFFLE, SWEDEN  
PHONE: +46 533 167 00  
FAX: +46 533 141 36  
E-mail: sales@somas.se  
www.somas.se

Representative